

BAJAJ CONEGALE INCLINED CLEANER

96" and 120" Widths



First Stage Cleaning Inclined Cleaner over Stick Machine. Hanging Guards were removed for photographic illustration.



Second Stage Cleaning Inclined Cleaner over Impact Cleaner

Versatile, Efficient, Rugged - Quality Engineered.
Continental Eagle's Inclined Cleaner is designed to meet your ginning requirements.

Unsurpassed in seed cotton conditioning and trash removal, Bajaj Coneagle's Inclined Cleaners are a vital part of the "balanced Outfit" that provide optimum capacity, high quality and increased profits. Working alone or in combination with other cleaners, the Bajaj Coneagle inclined Cleaner can be used in numerous arrangements. The choice of 96" or 120" width assures you of getting just the right cleaner for your individual ginning requirements.

Every feature of the Inclined Cleaner is designed for maximum efficiency and performance. Twin intels provide full-width distribution of seed cotton. The cog belt drive supplies positive, uniform power to all cylinders. Use of a multiple blade vacuum feeder at the discharge assures a smooth, even output at any capacity. Bajaj Coneagle's inclined Cleaner utilized individual grid bar screen for gentle trash removal and easy replacement.

The advanced engineering design of the spiked cylinder and grid bar screen insures removal of leaf, pin and pepper trash. Sturdiness and high quality are evident throughout the Inclined Cleaner's structural design. The heavy angle steel base frame means durability and longer life; reinforced heavy gauge doors, covers and dust hopper add rigidity to construction. Bearings and covers are sealed throughout, with sealing strips inserted between all bolted connections. Air and dust seals on all shafts provide for a sealed cleaner.

*Not Included

Shown without guards for brochure illustration....Never Operate Any Machinery Without Safety Guards & Lock It Out For Maintenance

BAJAJCONEGALE INCLINED CLEANER

96"and120"Widhts

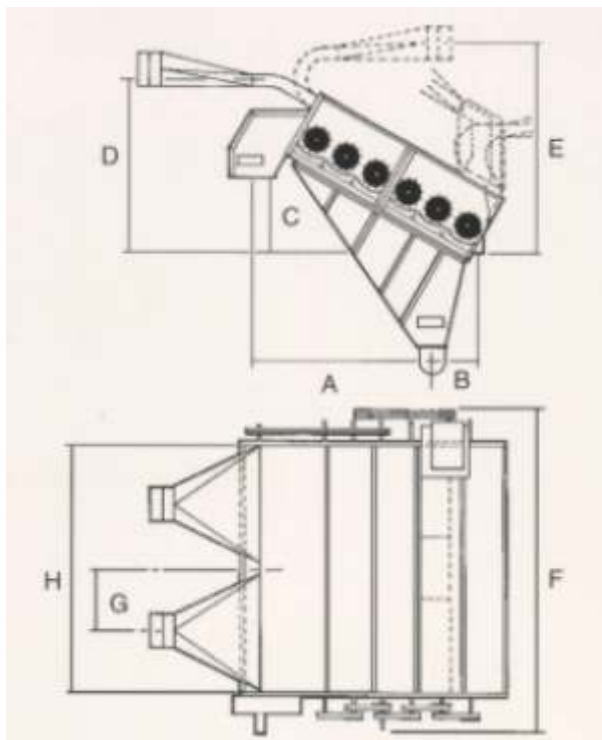

Grid Bar Section



First Stage Cleaning
Inclined Cleaners over Stick Machines

Dimensions

	96"(2438)	120" (3048)
A	7' 4-15/16" (2259)	7' 1-15/16" (2182.8)
B	1'7-5/8" (498.5)	1'10-5/8" (574.7)
C	3' 1-1/4" (976)	3' 1-1/4" (976)
D	7' 3-5/8" (2225.7)	7' 3-5/8" (2225.7)
E	8' 3-3/8" (2524)	8' 3-3/8" (2524)
F	11' (3352.8)	13' (3962.4)
G	2'2-1/2" (673)	2'8" (812.8)

Technical Specifications

Capacity	25-30 Bales per hour - 120 in. 20-24 Bales per hour - 96 in.
Cleaning Screen:	
Type	Grid Bar
Distance between bars	5/8 in. (16mm)
Electric Motor (not included)	15 hp (11 kw)
Number	6
Diamete	15-1/2 in. (394 mm)
Shaft Diameter	2-3/16 in. (55.6 mm)
Weight	13.000 lb. (5897 kg) - 120 in 9.000 lb. (4445 kg) - 96 in.

- Used as Gravity Cleaner or as Hot Air Cleaner in Drying System.
- Individual Grid Bar Screens for gentle trash removal and easy replacement.
- Extraordinary removed of large and small trash - leaf, pin and pepper.
- Sealed bearing though out for absolute minimum maintenance.
- Cog Belt Drive assures positive uniforms power to all cylinders.
- Twin intels for full width distribution of seed cotton.
- Heavy steel construction for longer life.
- Reinforced heavy gauge doors, covered and Dust Hopper add rigidity to construction. Covers are sealed with felt packing and sealing strips are inserted between all bolted connections.
- Easy accessibility for maintenance.
- Air and Dust Seals on all shafts minimize dust emission.

Spiked Cylinder Design



All designs, specifications and ratings are subject to change without notice.



Manufactured and Marketed By

BAJAJ STEEL INDUSTRIES LIMITED

IMAMBADA ROAD, NAGPUR- 440 018, INDIA
Tel: +91-712-272 0071 ~ 80 Fax: +91-712-272 3068
email : ceccsales@bajajngp.com / bsi@bajajngp.com
website : www.bajajngp.com



BAJAJ CONEAGLE LLC

1900 Market St., Millbrook, AL 36054, USA
Telephone: (334) 517-6139/40/41 Fax: (334) 571-6142
email: sales@bajajconeagle.com
website: www.bajajconeagle.com